



HEOS HomeCinema QUICK START GUIDE

HS2

BEFORE YOU BEGIN

The HEOS HomeCinema is designed to enhance the sound of your TV and allow you to enjoy HEOS Wireless Multi-Room Sound.

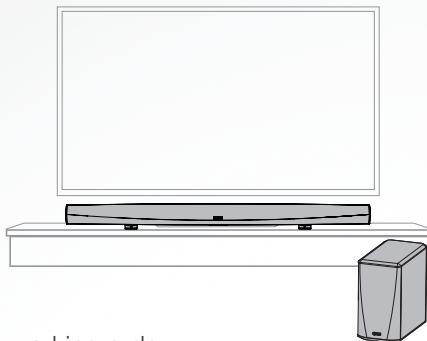

Make sure you have the following items in working order:



Wi-Fi
Router



Internet
Connection



Apple iOS, Android or Kindle
mobile device connected
to your network

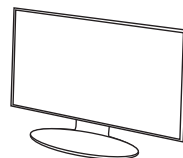

TV

STEP 1: UNPACK

Carefully unpack your HEOS HomeCinema.

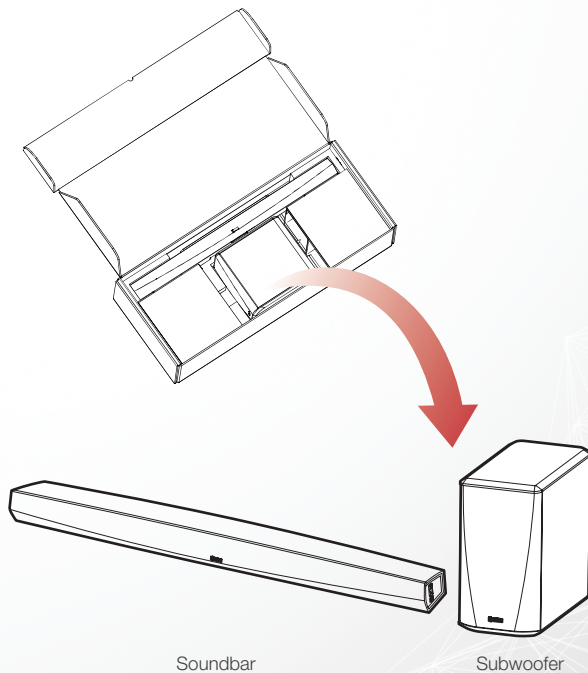

STEP 1: UNPACK

Verify that the following items are included in the accessories box.



3.5 mm
stereo cable

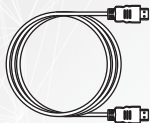

HDMI cable

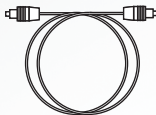

Digital optical cable



Ethernet cable



IR blaster



Power cords

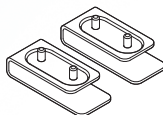

feet



Wall mount bumper
pads for Soundbar



Non-skid pads
for Subwoofer

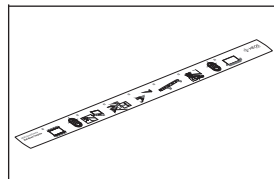

Wall mount template

STEP 2: PLACE

PLACING THE SOUNDBAR

Place the HEOS HomeCinema at a convenient location near the TV.

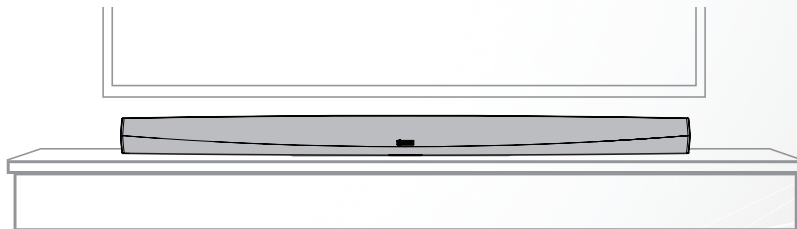

OPTIONAL

The HEOS HomeCinema Soundbar can be wall-mounted using the integrated keyhole mounts. Please refer to the wall mount template located behind the Soundbar in the product carton.

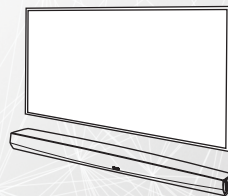

English

Français

Español

Deutsch

Nederlands

Italiano

Svenska

Dansk

Norsk

Pусский

Polski

STEP 2: PLACE

OPTIONAL

Attach the supplied feet if you need to raise the Soundbar over your TV stand base.

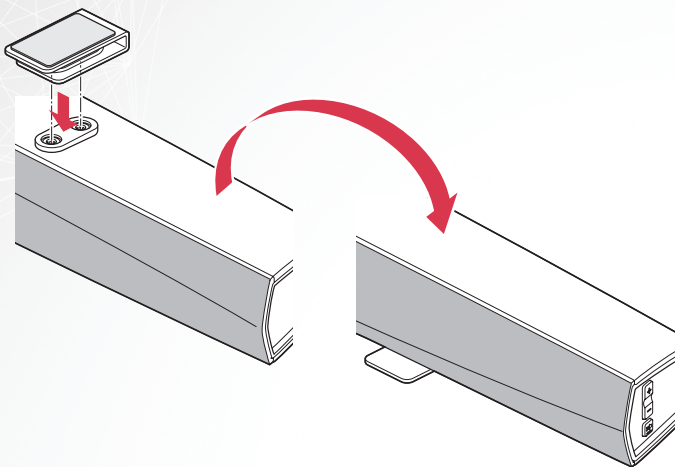

STEP 2: PLACE

PLACING THE SUBWOOFER

- 1 Attach the included non-skid pads to the four corners of the Subwoofer's side or bottom if you are placing it on a hard surface.
- 2 Place the Subwoofer in a convenient location on the floor near the Soundbar.

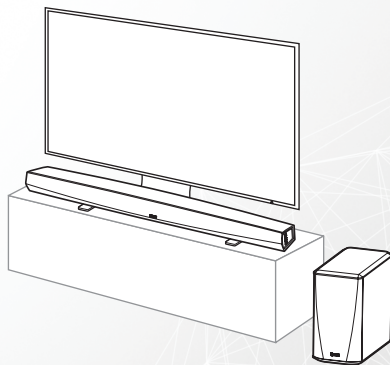
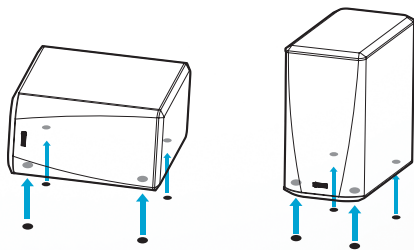

STEP 3: CONNECT

Connect the power cord between the Soundbar and a wall outlet and the power cord between the Subwoofer and a wall outlet.

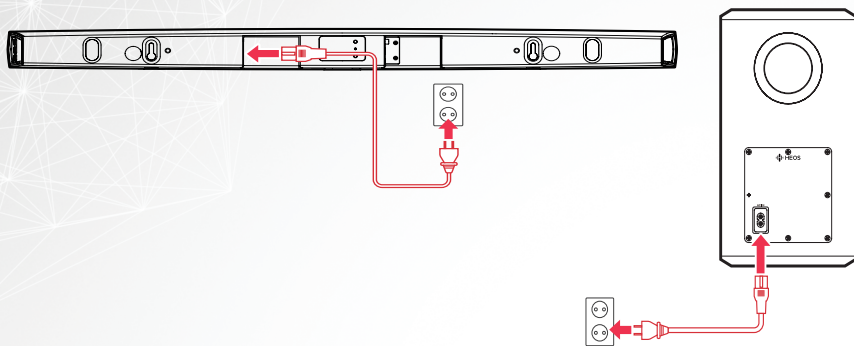

OPTIONAL

If you are connecting the HEOS HomeCinema to a wired network, connect the included Ethernet cable between the HEOS HomeCinema and your router.

Do not connect the Ethernet cable if you are connecting your HEOS HomeCinema to a wireless network.

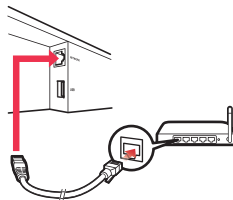

STEP 3: CONNECT

OPTIONAL

If you are wall mounting your HEOS HomeCinema you can skip this step.

- 1 Connect the IR blaster to the “IR OUT” jack on the back of the Soundbar.

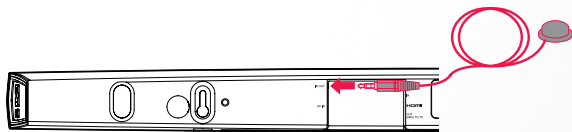

- 2 Peel off the backing and affix the blaster to the Soundbar so that it directly faces the IR receiver on your TV.

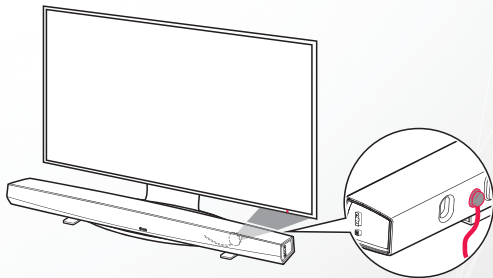

Note: The location of the IR receiver may be different on your TV. Please consult your TV manual.

STEP 4: CONTROL

- 1 Download the HEOS App
Go to the Apple App Store, Google Play or Amazon App Store and search for “HEOS” to download and install.



- 2 Launch the HEOS App
and follow the instructions in the app to complete the setup and configuration of the HEOS HomeCinema.



STEP 5: ADD DEVICE

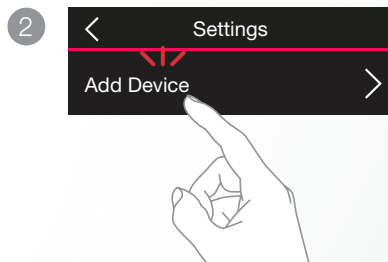
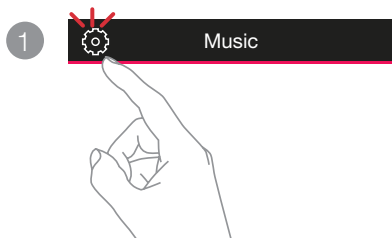

ENJOY!

OWNER'S MANUAL

- For more information, visit www.HEOSbyDenon.com
- Refer to the Online Manual for other functions information and operation procedure details.
manuals.denon.com/HEOSHCHS2/ALL/EN

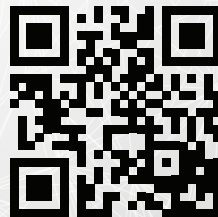

BASIC TROUBLESHOOTING

My HEOS device won't connect to my network using the audio cable

- Make sure your mobile device is connected to your wireless network before setting up your HEOS device.
- Alternatively, you can connect your HEOS device to your network router using the included Ethernet cable. Once connected via Ethernet, the HEOS by Denon App should recognize the HEOS device and you can manually move it to your wireless network using *Settings/My Devices/Device_Name/Advanced/Network Settings*.

Music cuts out or delays sometimes

- Make sure your Internet connection is operating correctly.
- If you are sharing your network with other users or devices, they may be using most of your bandwidth (especially if they are streaming video).
- Make sure your HEOS devices are within range of your wireless network.
- Make sure your HEOS devices are not located near other electronic devices that could interfere with its wireless connectivity (like microwave ovens, cordless phones, TVs, etc...).

No Subwoofer sound, sound interrupted, or noise occurring

- Check that the status LED is lit in blue on the Subwoofer. When the Status LED is lit in amber, disconnect from the wall outlet and then reconnect to it, or try to pair again.
 1. Press the Pair Button on the Subwoofer until the Status LED flashes amber rapidly.
 2. Press the Pair Button on the back of the Soundbar. The Status LED on the Subwoofer will be solid blue.
- When there is an obstacle between the Soundbar and the Subwoofer, remove it or place the Subwoofer closer to the Soundbar.

Cannot pair a Bluetooth device with the HEOS device

1. Activate the Bluetooth setting on your mobile device.
2. Press and hold the Bluetooth button (📶) located on the back of the Soundbar for 3 seconds and release the button when you see a pattern of two green flashes on the status LED.
3. Select "HEOS HomeCinema" from the list of available Bluetooth devices.

Connecting to a network using an iOS device

- This HEOS device supports Apple's "WAC (Wireless Accessory Configuration)" setup mode. WAC setup mode allows you to connect your HEOS device to your network without requiring you to type in the network name and password.
 1. The LED on the rear of the HEOS device will slowly blink amber to indicate that WAC setup mode is active. If the rear LED is not blinking amber, press and hold VOLUME DOWN and MUTE buttons for 3 seconds until you see the LED blinking amber.
 2. Go to the Wi-Fi menu under Settings on your iOS device.
 3. Select "HEOS HomeCinema" under "SET UP NEW AIRPLAY SPEAKER..." at the bottom of the list.
 4. Select the network you want your HEOS device to connect to and select "Next".
 5. Follow the instructions on the screen to complete setup.
 6. When the connection is complete, the LED on the front of the HEOS device will turn solid blue.
- HEOS will stay in WAC setup mode for 15 minutes. If the device is not setup within 15 minutes, it will revert back to its previous network connection. Press the Mute button if you want to cancel WAC setup mode.

Connecting to a network using WPS

- If your wireless router support WPS (Wi-Fi Protected Setup™) your HEOS wireless device can optionally connect to your network using the "Push Button" method by following these steps:
 1. Press the WPS button on your router.
 2. Within 2 minutes, Press and Hold the Connect button on the rear panel of the HEOS device for 3 seconds.
 3. The LED on the front of the HEOS device will flash green for several seconds as it connects to your router.
 4. When the connection is complete, the LED on the front of the HEOS device will turn solid blue.

Resetting Your Device

- Resetting your HEOS device will clear out the wireless network settings, EQ, and name but retain it's current software. You will have to use Settings->Add Device to reconnect the device to your home network before it can be used.
- To reset your HEOS device, press and hold the Connect and Bluetooth buttons located on the back of the HEOS device for 5 seconds until the front LED begins to flash amber

The HEOS by Denon app and brand is not affiliated with any manufacturer of any mobile device.

HEOS and the HEOS logo are trademarks or registered trademarks in the US and/or other countries.

Apple and the Apple logo are trademarks of Apple Inc., registered in the U.S. and other countries. App Store is a service mark of Apple Inc.

Google Play is a trademark of Google Inc.

Amazon, Kindle, Echo, Alexa, Dash, Fire and all related logos are trademarks of Amazon.com, Inc. or its affiliates.

Wi-Fi Protected Setup™ logo is trademark of Wi-Fi Alliance.

The Bluetooth® word mark and logos are registered trademarks owned by Bluetooth SIG, Inc. and any use of such marks by D&M Holdings Inc. is under license. Other trademarks and trade names are those of their respective owners.

All other trademarks are the property of their respective owners.

CONTACT Denon

If you need additional help in solving problems,
contact Denon customer service in your area
or visit [HEOSbyDenon.com](https://www.heosbydenon.com)





DENON[®]

HEOSbyDenon.com

Printed in China 5411 11563 00AD
Copyright ©2018 D&M Holdings Inc. All Rights Reserved.